

PERRY HOLT

PROPERTY CONSULTANTS

FOR SALE

Freehold workshop

31A Benskin Road, Watford, WD18 0HN

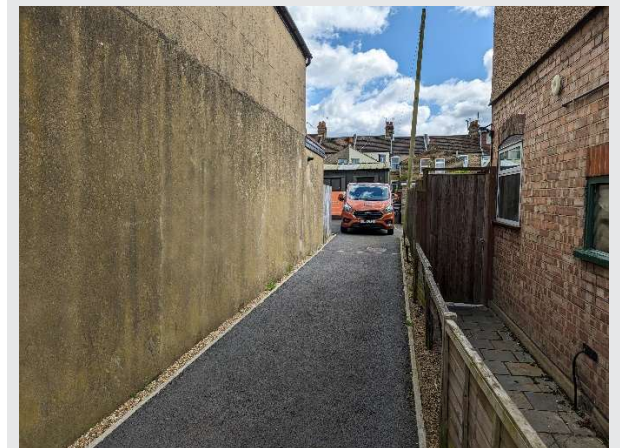
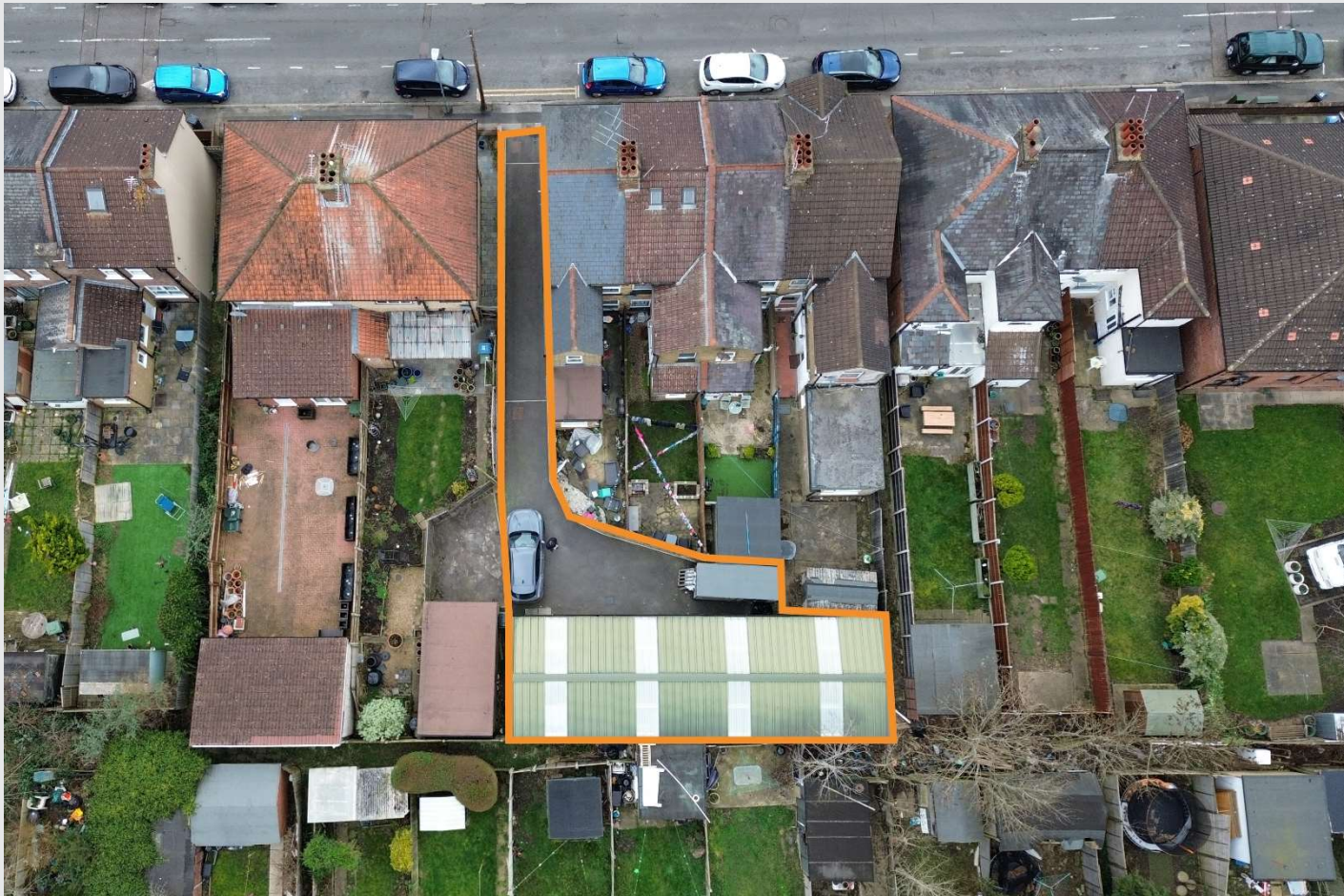

ACCOMMODATION

	Sq ft	Sq m
Workshop	640	59.4
Office/kitchen	208	19.3
Total	848	78.7

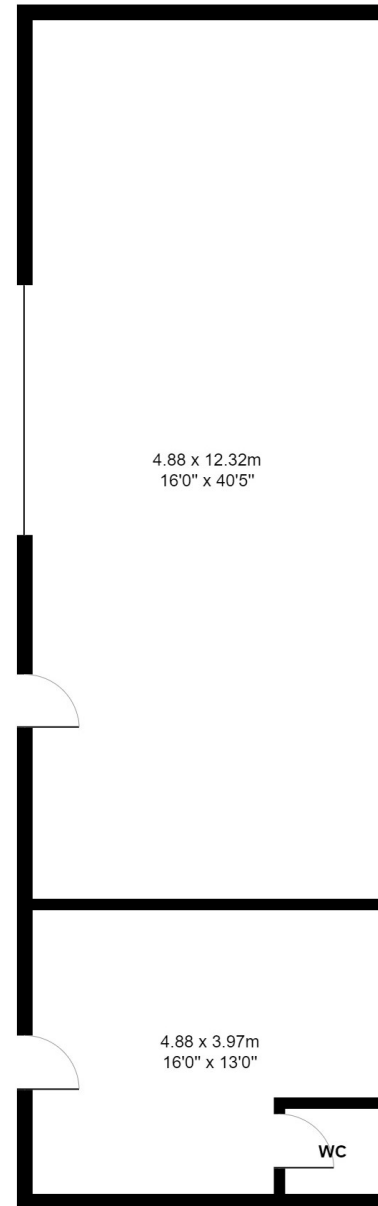

All measurements are approximate.
Please note this floor plan is for marketing purposes and is to be used as a guide only.
All efforts have been made to ensure accuracy.

AMENITIES

- ✓ Rarely available freehold interest opportunity
- ✓ Modern workshop premises
- ✓ Vacant possession
- ✓ £275,000 for the Freehold interest, subject to contract

LOCATION

Situated 1.5 miles from Watford Town Centre, the site is in a convenient position being walking distance to both Atria Watford and Watford General Hospital. Watford Metropolitan Station is only 0.9 miles from the location which offers fast rail connectivity into London and Watford Junction is 1.5 miles away. The site offers good road connectivity to Junction 5 of the M1 which is 2.9 miles from the site and Junction 19 of the M25 which is 3.1 miles away.

DESCRIPTION

Rarely available, single story workshop unit of approximately 848 sq ft which includes an office with kitchen area benefitting from 2 parking spaces. The unit is to be sold with vacant possession.

NB. No. 33 Benskin Road has right of access under licence to their garage located adjacent to 31A Benskin Road.

PRICE

£275,000 for the Freehold interest.

RATES

Rateable value: £9,300 Rates payable 23/24 £4,640.70

Rates payable should be verified with Watford Borough Council 01923 278466

VAT

We understand that VAT is not currently payable on the purchase price.

LEGAL COSTS

Each party to be responsible for their own legal costs.

PERRY HOLT

PROPERTY CONSULTANTS

FIRST FLOOR OFFICES 165-167 HIGH STREET
RICKMANSWORTH HERTS WD3 1AY

perryholt.co.uk

JOEL LOBATTO

ASSOCIATE DIRECTOR

07786 928311

01923 239080

joel@perryholt.co.uk

BEN HOWARD

ASSOCIATE DIRECTOR

07527 709064

01923 239080

ben@perryholt.co.uk